



Laser Cleaning Introduction

- 1 Profile**
- 2 Contaminant Existence Styles**
- 3 Laser Cleaning Principle**
- 4 Laser Cleaning Advantage**
- 5 Laser Cleaning Methods**
- 6 Laser Cleaning Application**

Profile

After nearly forty years` development, laser technology has been improved better and better everyday, and being widely used in industrial production, medical, military and entertainment industries. Laser cleaning technology is a new technology that developed in recent decades, related research started in the middle of 80s, but until the early 90s began by researchers attention and rapid development, its emergence has opened a new field of laser technology application in industry, and became a new member of the big family of laser processing in. Laser cleaning technology as a new cleaning technology, has become the supplement and extension of traditional cleaning methods, and has been applied in the field of microelectronics, construction, nuclear power, aerospace, automotive, medical, cultural relic protection.

Contaminant

The bonding force between the contaminant and the surface is mainly covalent bond, double dipole, capillary action, hydrogen bond, adsorption force and electrostatic force. Among them, capillary force, adsorption force and electrostatic force (Figure 1) are the most difficult to destroy.

Note: capillary force from a thin liquid layer (such as atmospheric humidity) in the particle and the surface of the primary layer and the small gap between the cohesion; adsorption force is the main adhesion of micron pollutants

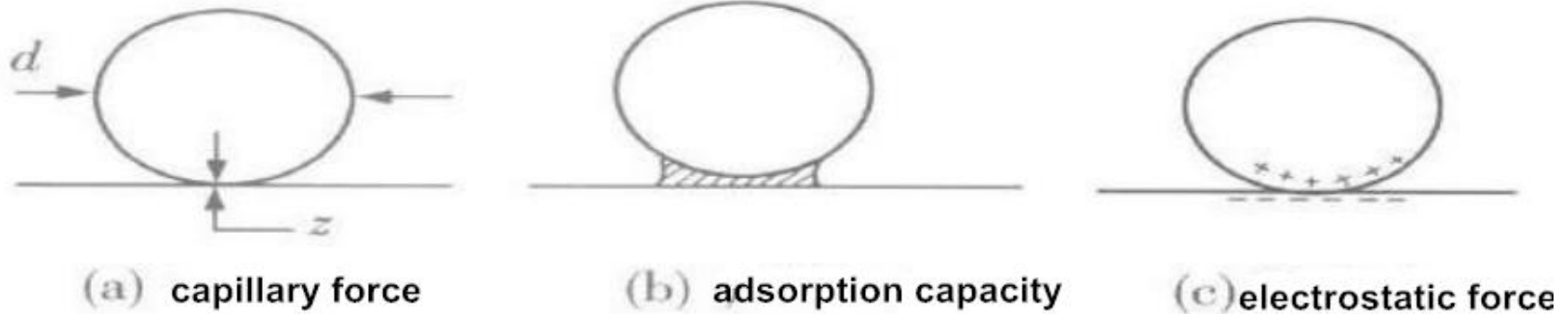
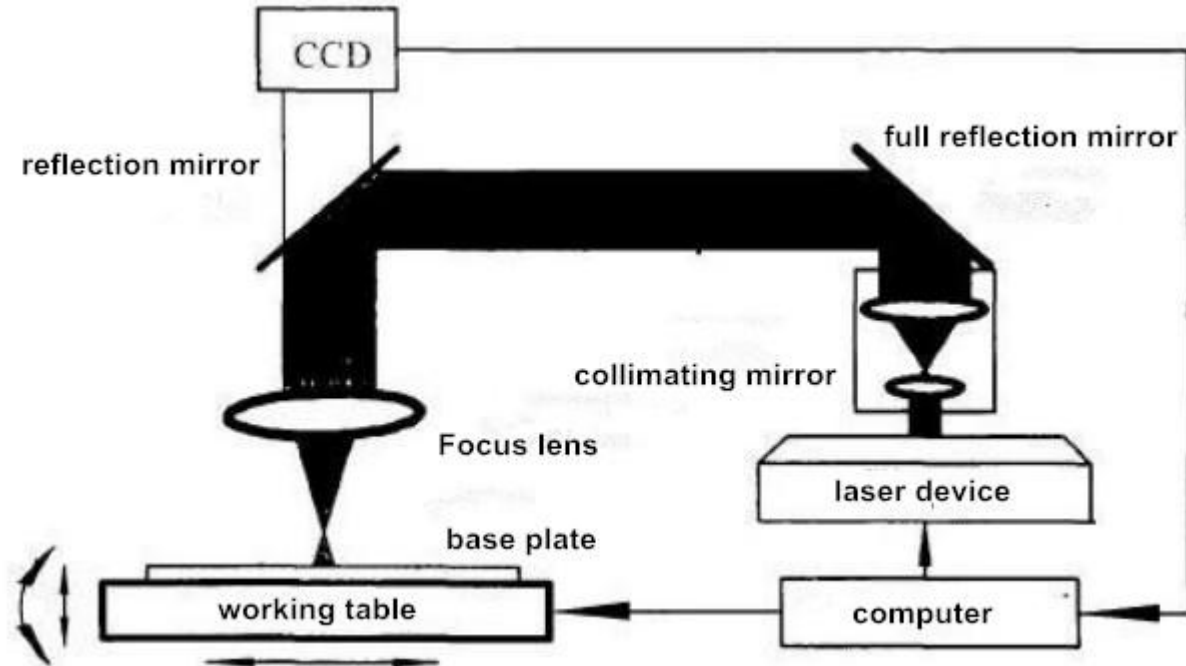

Figure 1 3 kinds of bonding force of contaminant and solid surface

Principle



Laser beam can produce at least 3 functions:

- 1 in the solid surface to produce a mechanical resonance phenomenon, is the surface of the dirt layer or condensation debris;
- 2 the surface dirt layer is heated and expanded, so as to overcome the adsorption force of the basic material to the dirt particles and the surface of the object is separated from the surface of the object;
- 3 instant to make the dirt molecules evaporate, gasification or decomposition

System Info



Our company's laser cleaning system is a new generation of industrial surface cleaning high-tech products. The use of international advanced laser, laser optical systems and control systems, to meet the requirements of metal surface cleaning process. To provide convenient, as small as 10 watt low power washing machine, up to 1000W, and the formulation of special cleaning system according to customer demand, can meet the requirements of laser surface degreasing, rust, paint, zinc film coating laser removing by laser cleaning technology.

System Info

Product features:

Rapid, clean, accurate cleaning, removal of surface coatings and contaminant;

No damage to the substrate processing equipment;

Can be used for a long time, low operation cost;

Automatic operation of equipment;

Application field:

Metal workpiece laser derusting, degreasing, laser paint removal, laser removal of zinc and film, laser coating removal, widely used in aerospace, mold,

microelectronics, construction, nuclear power plants, automobile manufacturing, medical, military etc

Advantage

Laser cleaning technology refers to the use of high energy laser beam irradiation surface of the workpiece, the surface of the dirt, rust, particles or coating flash evaporation or expansion stripping, so as to achieve the process of cleaning. Compared with traditional cleaning technology, laser cleaning technology has the following characteristics:

- (1) it is a "dry" cleaning, do not need cleaning solution or other chemical solution, will not lead to the two pollution, and cleanliness is much higher than chemical cleaning process;
- (2) the laser cleaning technology is very extensive, such as various oxide particles, rust, coating and organic matter on the surface;
- (3) the traditional cleaning method is often close to the operation, the substrate surface mechanical force, easy to damage the substrate; and laser cleaning is non-contact processing, remote operation can be carried out,

Advantage

By adjusting the laser parameters, on the basis of no damage on the surface of the substrate, the effective removal of pollutants, such as involution of the surface;

(4) with the aid of modern means, laser cleaning can easily realize automatic operation;

(5) laser decontamination equipment can be used for a long time;

(6) laser cleaning technology is a kind of "green" cleaning process, the elimination of waste is solid powder, small size, easy to store, basically no pollution to the environment.

Laser cleaning can be divided into metal laser cleaning, laser cleaning, laser cleaning, etc. according to the application of laser, the laser can be divided into solid pulse laser cleaning and fiber laser cleaning. Metal laser cleaning is mainly divided into laser degreasing, laser derusting, laser paint removal, etc..

Clean Methods

1. Laser dry cleaning method

Use pulses laser to clean rust directly, it will generate vibration after the laser energy is absorbed by the base or particles, then separate the base and contaminant.

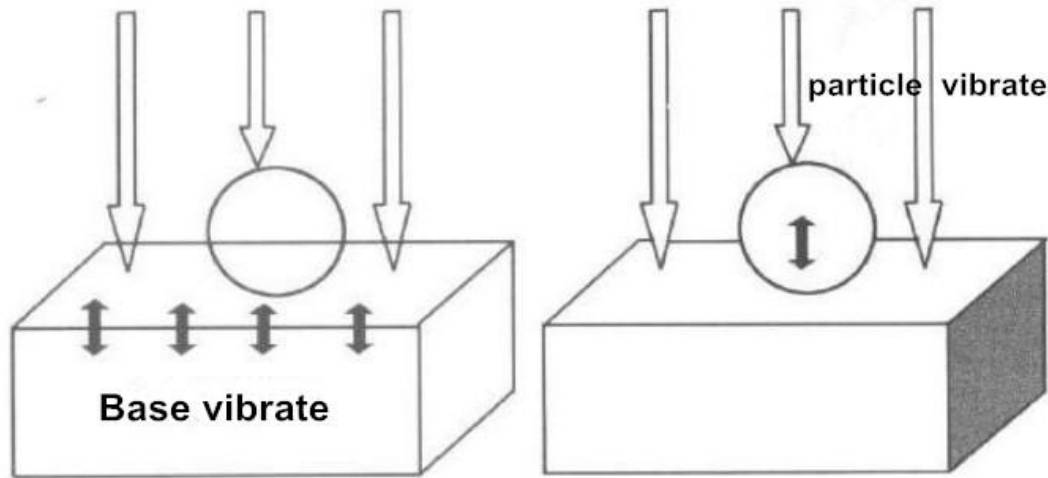

(a) laser absorbed by base (b) laser absorbed by particle

Figure 2 laser dry clean method dynamic process diagrammatic drawing

Clean Methods

2.laser+liquid film

First deposit a liquid film on surface of the base, then use laser to clean the comtaminant

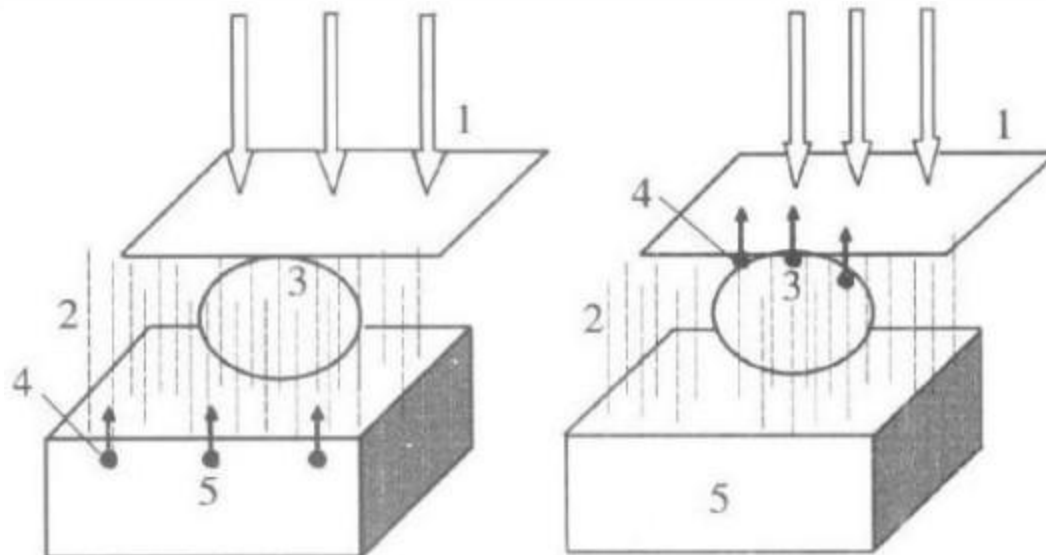

(a) laser absorbed by base completely (b) laser absorbed by particle completely

Figure3 laser liquid film clean method dynamic process diagrammatic drawing

1.laser; 2.liquid film; 3.comtaminant particles; 4.immediately volatilization; 5、 base

Clean Methods

3. Laser+inert gas

Use inert gas to flow the base surface then laser radiate, the contaminant will be flowed away after separated from base surface, in case the surface will be polluted and oxidized again.

4. Use laser to make the contaminant incompact, then use non-corrosive chemical methods to clean up. (only for stony historical relic)

Remove Rust

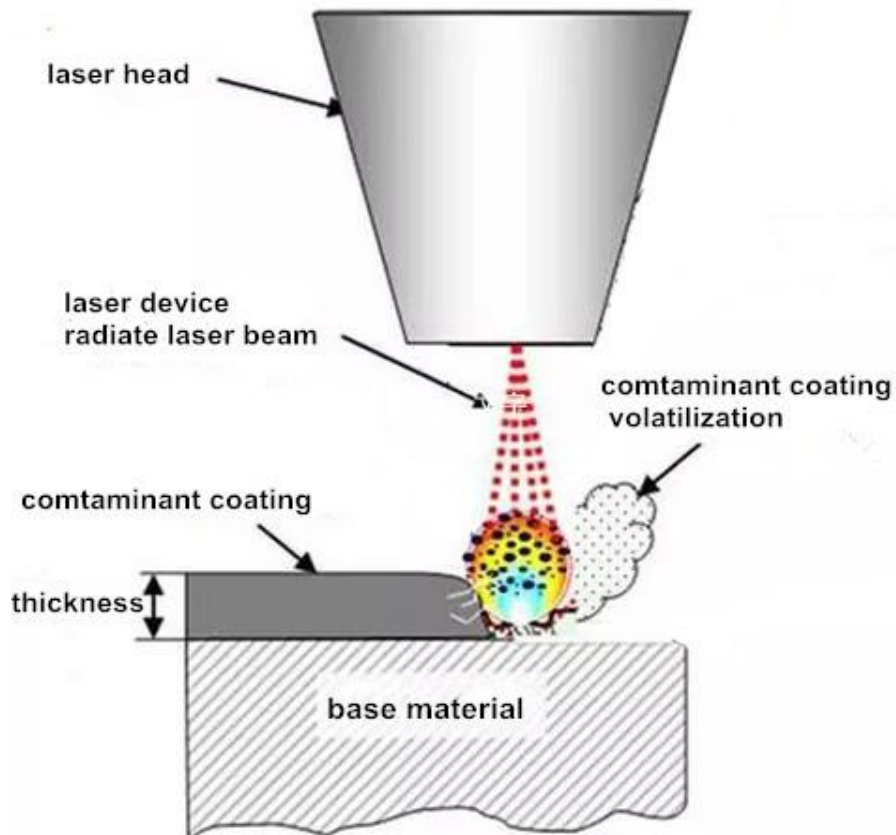

laser derusting schematic diagram

Laser derusting using laser high energy, high frequency, high power characteristics, the high energy instantly deposited in a small area, the use of high-temperature oxidation of the oxide layer.

Clean Methods

Engine laser rust removal



Remove Rust

Roller laser rust removal



Remove Rust

Mold laser derusting



Car rod laser rust removing



Remove Rust

**Laser
derusting**



Remove Paint

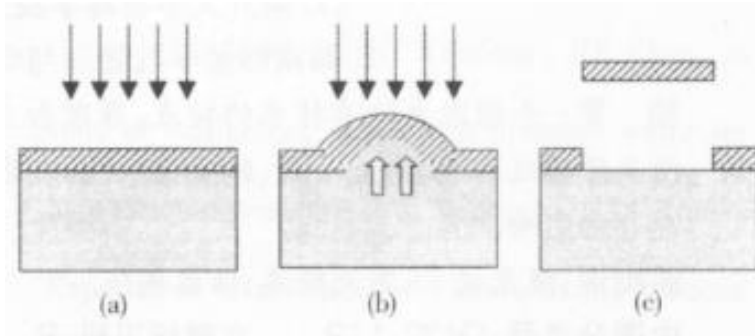

Figure4 Shaking principle

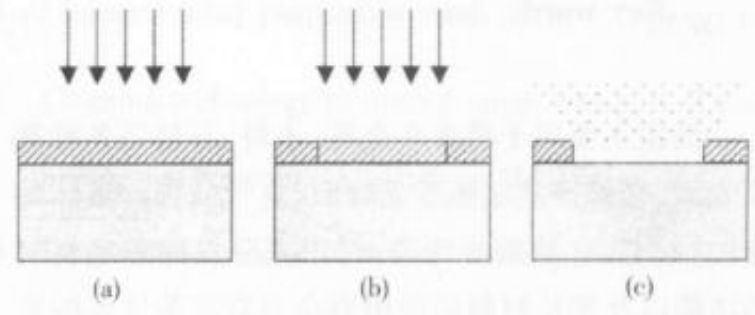

Figure5 Burning principle

The process of laser paint removal actually is the interaction of the laser beam between the base.

The paint coating and base will absorb some laser energy when the laser reflects on the surface of the paint coating, then the temperature of the paint coating and the base will increase, at the same time, the coating and base will get thermal expansion after high temperature. (Figure 4) The quick thermal expansion in a short time will generate strong vibration to resist anchoring strength and separate the two parts finally.

As mentioned before, the temperature of the paint coating and the base will increase when the laser reflects on the surface, for some very low transmittance paint coating, as the base is hard to absorb enough laser energy to make enough strong vibration, the paint will gasify after gaining relatively more laser energy, just like the paint coating is burned. We call this kind of laser paint method an ablation effect. (Figure 5)

Remove Paint

Air conditioning unit laser paint removal



Remove Paint

Plate laser paint removal



Remove Paint

**Laser
Paint
Removing**



Remove Oil

Engine oil filter net laser contaminant removal

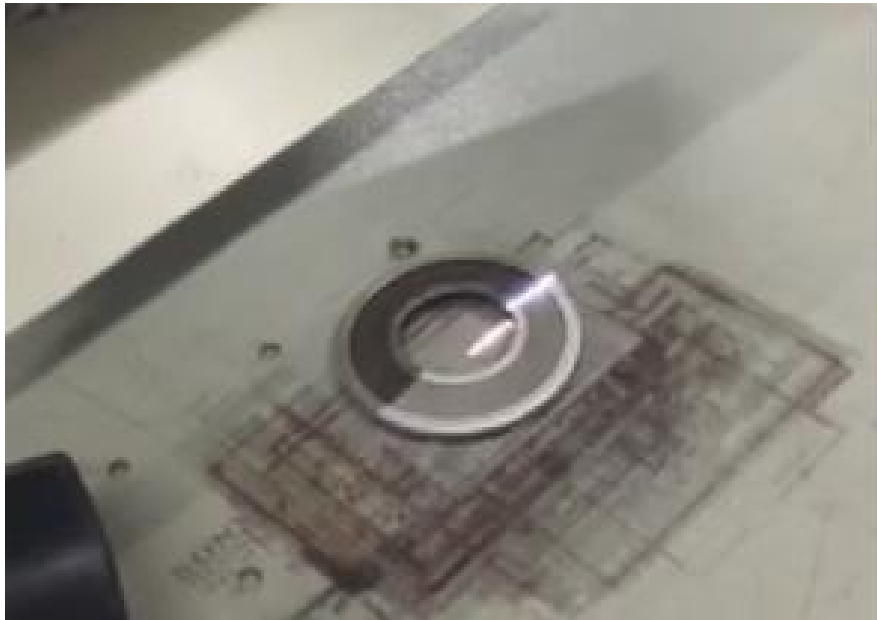

Before cleaning



After cleaning



Remove Oil

**Laser
Oil Contaminant
Removing**



Remove Oil

**Tank
chain
laser
oil
removal**



Remove Glue



There are two methods of laser glue removal: one is the high temperature from laser will burn and gasify the glue coating immediately; the second is the rubber particles on aluminum plate surface will splash after the rubber deeper layer getting thermal vibration and thermal shock of laser pulse.

Remove Glue

**Rubber mold
Laser
Glue
Removal**



Remove Oxide Coating

Welding lines laser oxide coating removal



The temperature will increase when the laser reflect on the surface of the oxide coating, the high temperature make the coating burned and gasified immediately.



Remove Oxide Coating

Welding lines
laser
oxide coating
removal

Before removal

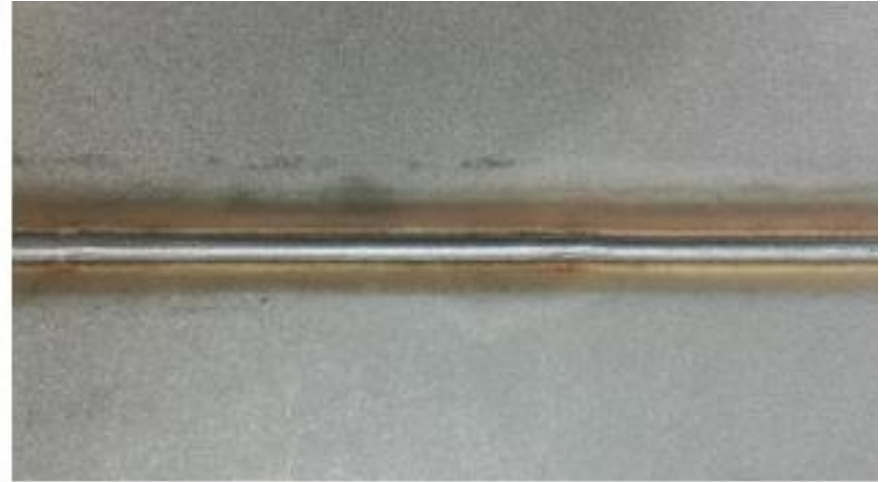

After removal



Conclusion

Laser cleaning technology can be used on liquid products, solid products, historical relic, air space, easy burned or broken products, so it is much safer, more efficient and reliable to use laser cleaning technology. It has high advantage on application of below industries: air plane and ship metal surface derusting , paint removal; building surface dirt cleaning; chip surface cleaning of micro electricy

Presumably, as the demands of the market increasing , the applications of laser cleaning technolog will be more widely.

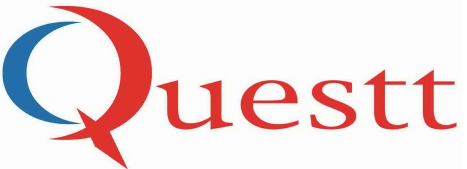

Laser Cleaning Project

Thanks !

Best regards
Mr.Andy Zuo
Manager

Wuhan QUESTT ASIA Technology Co., Ltd

Address: A7-101, Hangyu, WuDa Sci & Tech Park, East Lake Dev. Zone, Wuhan, Hubei, China

Zip: 430223

WhatsApp/Wechat:+8613294168619

Tel: 0086 27 87611146

Fax: 0086 27 59908808

Email: info@questtlaser.com

QQ: 2696898824

<http://www.questt.com.cn>

[Http://www.questtlaser.com](http://www.questtlaser.com)